

JA Standard Module Packaging Introduction

Packaging Introduction Packaging Introduction Packaging Introduction Packaging Introduction Packaging Introduction Packaging Introduction Packaging Introduction Packaging Introduction **For Single Glass Modules** Introduction Packaging Introduction Packag
2021.V1.0

JASOLAR

JA Solar Technology Co., Ltd.

Add: Building No.8, Nuode Center, Automobile Museum East Road, Fengtai District, Beijing,China

Tel: +86 (10) 63611888

Email: sales@jasolar.com

JASOLAR

Note:

This introduction is only for the JA Standard Module Packaging. All information is based on the following series module packaging:

JAM60S10 MR/ JAM68S11 PR(B)/ JAM72S10 MR/ JAM78S10 MR Series

JAM60S10 MB/ JAM72S10 MB Series

JAM60S20 MR/ JAM72S20 MR Series

JAM72S17 GR Series

JA Solar reserves the right to make changes to the packaging specification without prior notice.

1. Basic Knowledge

No.	Module Type	Module				Dimension of packaging					40HQ Container	
		Dimension of module			Weight	Dimension of packaging -case (with pallet)			Module QTY Per Pallet	Weight	Pallet QTY per container	Total Module QTY
		L	W	H		L	W	H				
		[mm]	[mm]	[mm]	[kg]	[mm]	[mm]	[mm]	[kg]	[Pallet]		
1	JAM60S10 MR Series	1689	996	35	18.7±3%	1735	1145	1130	31	610±3%	26	806
2	JAM68S11 PR(B) Series	1638	1084	35	19.0±3%	1678	1145	1218	31	618±3%	28	868
3	JAM72S10 MR Series	2015	996	40	22.7±3%	2060	1145	1130	27	653±3%	22	594
4		2015	996	35	22.4±3%	2060	1145	1130	31	733±3%	22	682
5	JAM78S10 MR Series	2180	996	40	24.6±3%	2230	1145	1130	27	709±3%	20	540
6	JAM60S20 MR Series	1769	1052	35	20.2±3%	1794	1145	1182	31	663±3%	26	806
7	JAM72S20 MR Series	2112	1052	35	24.5±3%	2160	1145	1182	31	800±3%	22	682
8	JAM60S10 MB Transparent backsheet module Series	1711	1000	35	18.5±3%	1760	1145	1135	31	604±3%	26	806
9	JAM72S10 MB Transparent backsheet module Series	2037	1000	40	22.6±3%	2083	1145	1135	27	648±3%	22	594
10		2037	1000	35	22.5±3%	2083	1145	1135	31	738±3%	22	682
11	JAM72S17 GR Series	1960	996	30	19.0±3%	1990	1145	1126	36	730±3%	24	864

*JAM68S11 PR(B) Series not for sale,distribution or ues outside of Asia.

2. Packaging Steps

1) Lay up the plywood pallet.

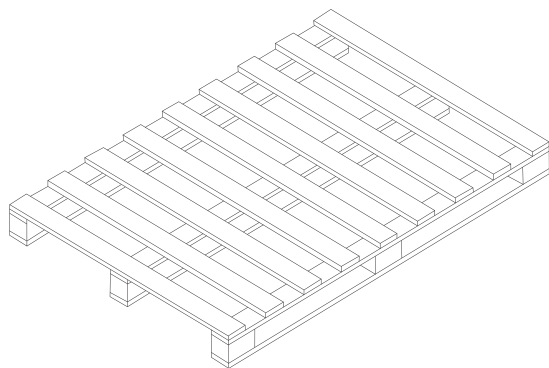

2) Attach the stacking corners to the modules.

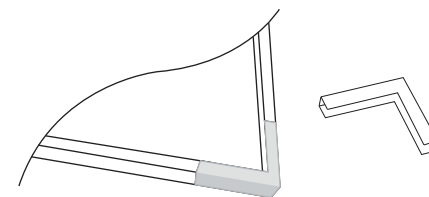

3) Place the modules on to the pallet with the first and last modules front side facing outwards.

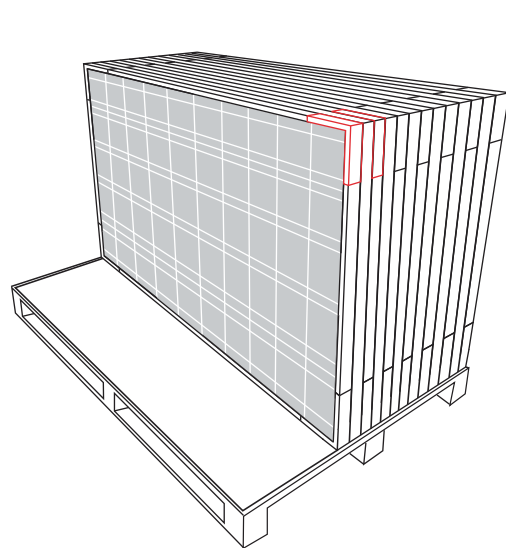

4) Firstly, use 2 pieces strapping bands vertically on the long side of the modules for fixing, then place 2 pieces the long hardboard corner piece on the diagonal of modules to protect the module edges, and use the strapping bands for fixing.

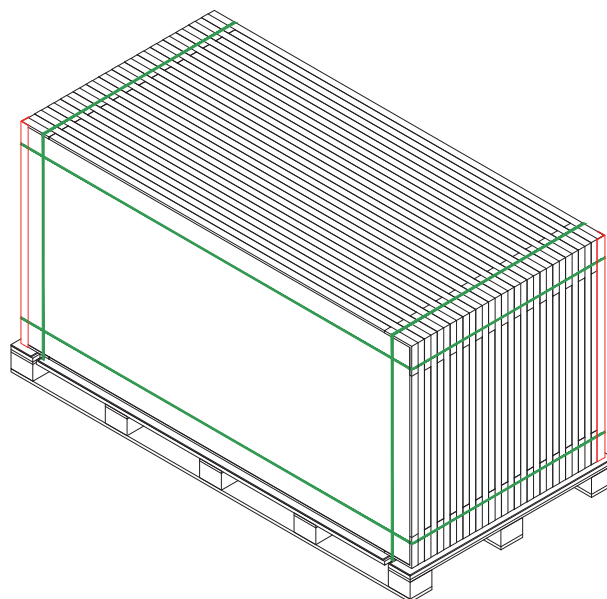

5) Place the cardboard surrounding piece around the modules.

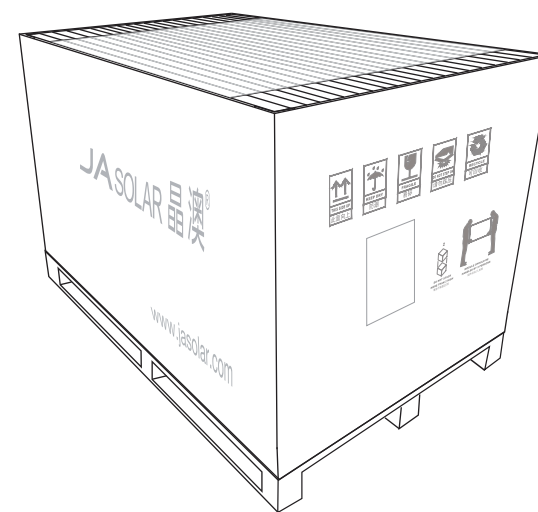

6) Place the cardboard cover on the package.

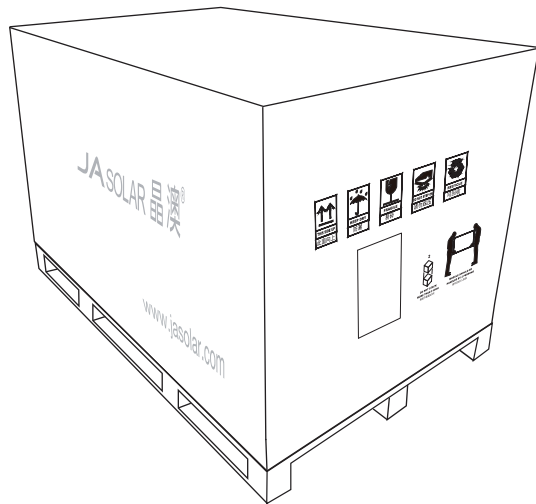

7) Attach the shipping marks on to the cardboard box.

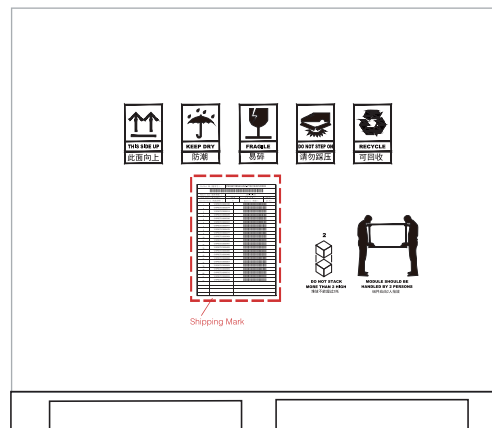
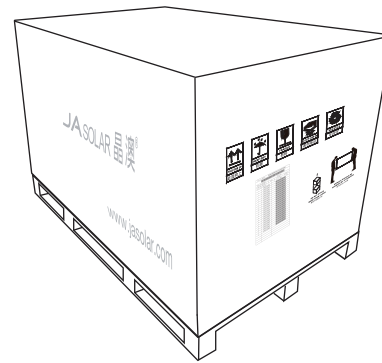

8) For JAMxxS10 series, first, use 1 piece strapping band at the middle side of the package for fixing, then use wrapping film to secure the package, and fix it with 4 pieces strapping bands to further stabilize the modules.

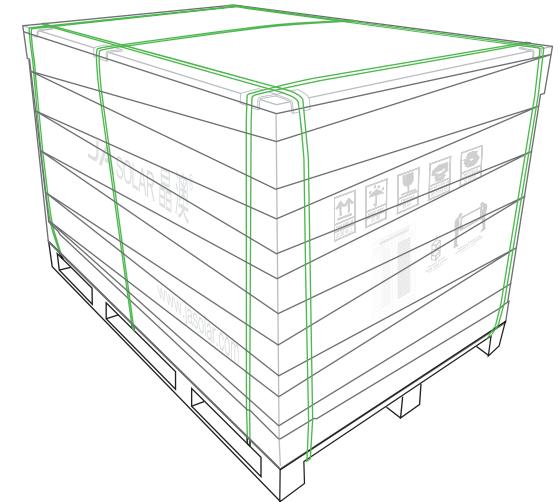

8) For JAMxxS20 series,use strapping bands to fix the package, place 4 pieces long hardboard corner piece on the diagonal of mudules to protect the module edges,and ues 2 pieces horizontal strapping bands for fixing.Then,use 1 piece stapping band at the middle side of the package for fixing,then use wrapping film to secure the package,and fix it with 4 pieces stapping bands to further stabilize the modules.

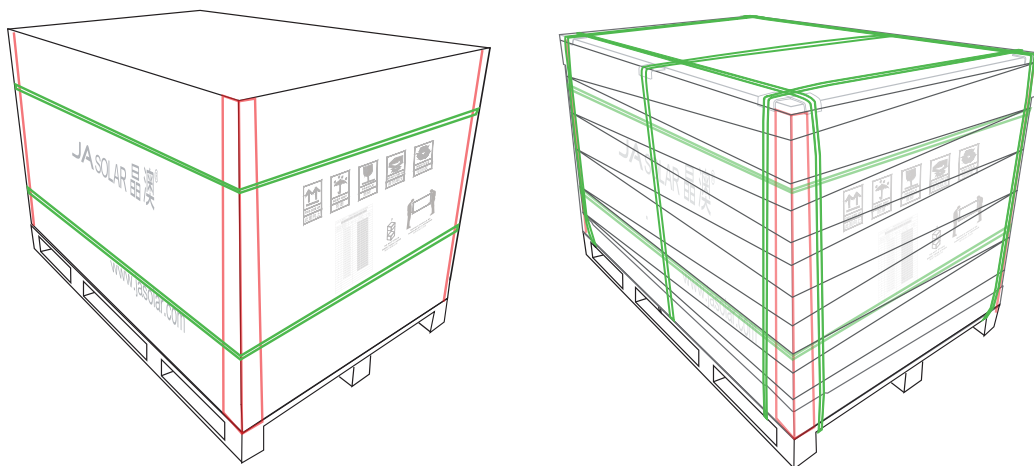

3. Stacking of the packages.

The packages can be piled up to a maximum of 2 layers.

